

Encoder models
Drehgebermodelle
编码器型号

861
862
865

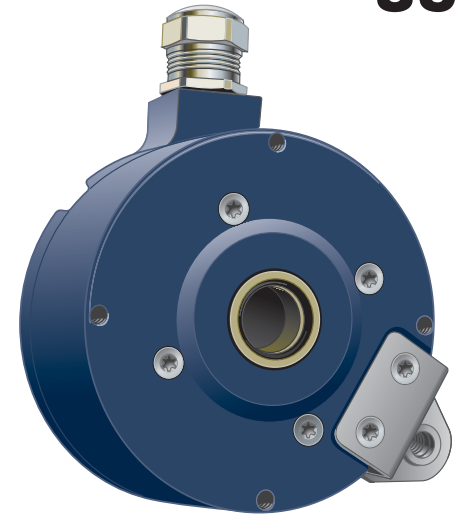

-  Mounting instructions
-  Montageanleitung
-  安装说明

LEINE  **LINDE**

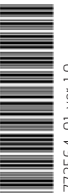

773564-01, ver. 1.0



Contact



Kontakt



联系我们



SWEDEN / SVERIGE (Head office)

T +46-(0)152-265 00

F +46-(0)152-265 05

info@leinelinde.se



中国

T +86-21-52 58 35 66

F +86-21-52 58 35 99

info@leinelinde.cn



DANMARK

T +45-862-308 34

F +45-862-306 21

info@leinelinde.dk



DEUTSCHLAND

T +49-(0)7361-78093-0

F +49-(0)7361-78093-11

info@leinelinde.de



INDIA

T +91-11-2617-2504

F +91-11-4058-2516

info@leinelinde.in



ITALIA

T +39-(0)39-596 01 08

F +39-(0)39-971 69 00

info@leinelinde.it



대한민국

T +82-55-266 2372

F +82-55-266 2373

info@leinelinde.co.kr



SUOMI

T +358-(0)9-561 72 00

F +358-(0)9-561 72 020

info@leinelinde.fi



Leine & Linde is a Swedish company dedicated to production of encoders for heavy duty applications. Some of the values offered by Leine & Linde are local technical support and possibility of 24 hours express delivery.

On our website www.leinelinde.com you can find

- data sheets and other product information
- detailed manuals and software for use with products with ADS™.



Leine & Linde ist ein schwedisches Unternehmen, das sich auf die Produktion von Drehgebern für den harten Einsatz in Gewerbe und Industrie spezialisiert hat. Dabei zeichnet sich Leine & Linde unter anderem durch kundennahen technischen Support und mögliche 24-Stunden-Expresslieferungen aus.

Auf unserer Homepage www.leinelinde.de finden Sie

- Datenblätter und sonstige Produktinformationen
- ausführliche Handbücher und Software zur Verwendung von Produkten mit ADS™.





莱纳林德是一家专门生产重工况应用编码器的瑞典公司。莱纳林德提供您的一些价值包括本地技术支持，以及可能安排 24 小时快递送货。

在我们的网站 www.leinelinde.cn 上，您可以找到

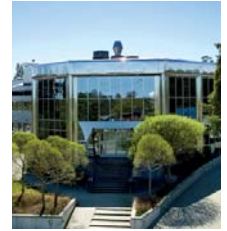
- 数据表与其他产品信息
- 详细使用手册和用于 ADS™ 产品的软件。





 The following models are fully covered by these mounting instructions:

 Folgende Modelle werden vollständig von dieser Montageanleitung abgedeckt:

 本安装说明全面涵盖下列型号:

 The following models have customised properties and may deviate slightly from these mounting instructions:

 Folgende Modelle besitzen kundenspezifische Merkmale und können daher geringfügig von dieser Montageanleitung abweichen:

 下列型号包含有定制特性，可能与本安装说明略有差异:

**861-
862-
865-**

**8619-
8629-
8659-**

1



Parts of the products



Produkteile



产品部件

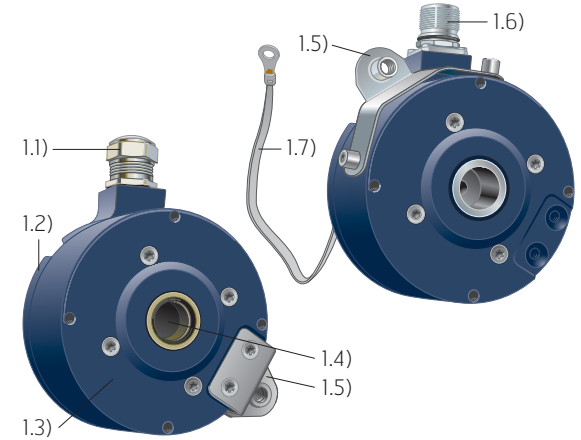

1.1 Cable gland
1.2 Terminal cover
1.3 Flange
1.4 Hollow shaft
1.5 Torque arm bracket
1.6 Connector
1.7 Earthing strap (optional)



1.1 Kabeldurchführung
1.2 Klemmendeckel
1.3 Flansch
1.4 Hohlwelle
1.5 Befestigung Drehmomentstütze
1.6 Anschlussstecker
1.7 Erdungsband (optional)



1.1 电缆密封接头
1.2 接线盒外壳
1.3 法兰
1.4 空心轴
1.5 扭矩支架
1.6 连接器
1.7 接地线 (可选件)

2



Risk of bodily injury



**Verletzungs-
gefahr**



人身伤害危险

2.1)



2.2)



Important before mounting begins:

- 2.1 Switch off the power.
- 2.2 Make sure the machine is at a standstill. The product is to be mounted on a rotating part that can cause bodily injury when in motion.



Wichtig! Vor Beginn der Montage:

- 2.1 Strom ausschalten.
- 2.2 Sicherstellen, dass die Maschine stillsteht. Das Produkt wird auf einem rotierenden Teil montiert, das im Betrieb eine potenzielle Verletzungsgefahr darstellt.



安装前注意事项:

- 2.1 关闭电源。
- 2.2 确保机器处于停机状态。本产品安装在旋转部件上，在运动状态下操作可能导致人身伤害。

3



Risk of damage to the product



Beschädigungsgefahr



产品损坏风险

3.1)

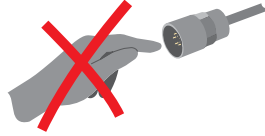

3.2)

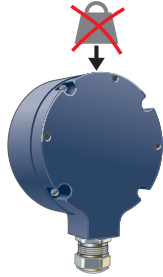

3.3)



3.4)

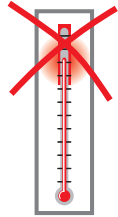

3.5)



3.6)

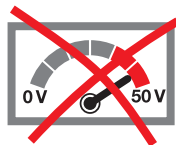

3.7)



The product is a precision measuring instrument. It should be handled with care, by experienced personnel. The warnings below apply in the event of effects outside the limit values stated in the product's data sheet.

The product may be damaged

- 3.1 by ESD discharges if the electronics are touched
- 3.2 if the shaft is exposed to high mechanical forces
- 3.3 by moisture or chemical fluids (do not install cable pointing upwards)
- 3.4 if it is exposed to extreme temperatures
- 3.5 if it is exposed to powerful vibrations or shock
- 3.6 by short-circuits or an excessively high supply voltage
- 3.7 by impacts or knocks or other physical damage.



Dieses Produkt ist ein Präzisionsmessgerät. Es muss daher von geschultem Personal mit Sorgfalt behandelt werden. Die nachfolgenden Warnhinweise gelten für Einwirkungen, die außerhalb der im Produktdatenblatt angegebenen Grenzwerte liegen.

Schäden am Produkt können durch Folgendes verursacht werden

- 3.1 durch elektrostatische Entladung bei Berühren der Elektronik
- 3.2 durch zu starke Kräfte an der Welle
- 3.3 durch Feuchtigkeit und chemische Flüssigkeiten (keine nach oben gerichteten Kabel anbringen)
- 3.4 durch extreme Temperaturen
- 3.5 durch zu starke Vibrationen und Erschütterungen
- 3.6 durch einen Kurzschluss oder eine zu hohe Betriebsspannung
- 3.7 durch Schläge, Stöße oder andere physische Einwirkung.



本产品为精密测量仪器。应由有经验的人员小心操作。以下警告适用于，产品在超出技术规范极限值情况下使用。

产品在下列情况下可能损坏

- 3.1 电子产品被接触时的静电放电
- 3.2 轴上作用力过大
- 3.3 潮湿或化学液体腐蚀（不要竖直安装电缆）
- 3.4 极限温度下
- 3.5 剧烈振动或冲击
- 3.6 短路或供电电压过高
- 3.7 遭受敲打，撞击或其他物理损坏。

4.1



Mounting of hollow shaft



Montage der Hohlwelle



安装空心轴

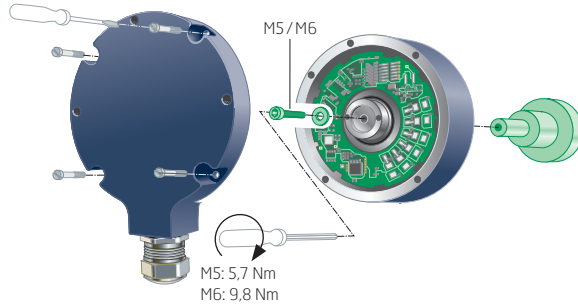

4.2



Mounting of torque arm



Montage der Drehmomentstütze



安装扭臂

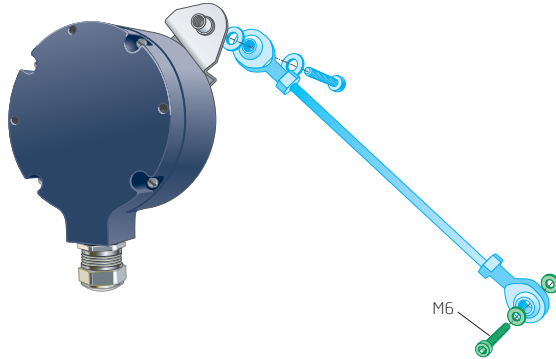

4.3



Alternative mounting of torque arm





Alternative Montage der Drehmomentstütze



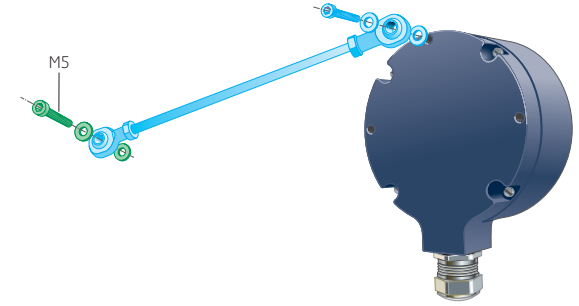

可选安装扭臂





-  Part from customer
-  Accessories from Leine & Linde (to be ordered separately, see page 20)
-  Tools for mounting



-  Kundenkomponente
-  Zubehör von Leine & Linde (separate Bestellung, siehe Seite 20)
-  Montagewerkzeug



-  客户部件
-  莱纳林德附件 (需单独订购, 参见第 20 页)
-  安装工具

5



Check points for mechanical mounting



Kontrollpunkte bei mechanischer Montage



机械安装检查要点

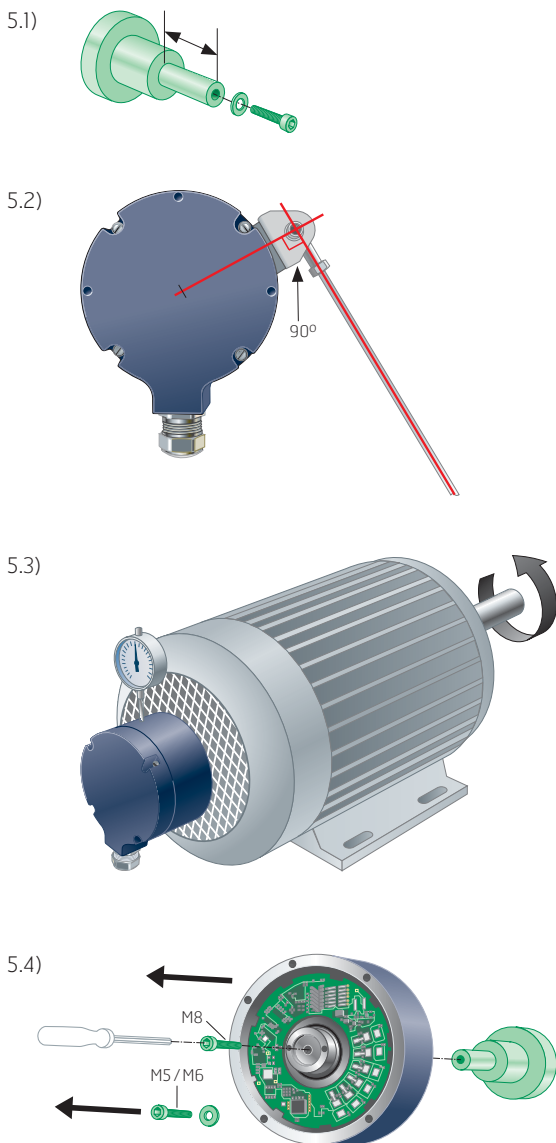

- 5.1 Check that the dimensions of the mating shaft match the specifications in the encoder's data sheet. Fix the encoder with an M5 or M6 screw (ISO 4762) with minimum 9 mm thread in use.
- 5.2 Fix the encoder with an insulated torque arm. It must be fitted at 90 degrees angle to the direction of the bracket, for optimum accuracy of measurement.
- 5.3 Check the encoder's radial runout with slow rotation of complete assembly. The runout should not exceed 0.1 mm, as this may shorten the encoder's service life or influence the system accuracy.
- 5.4 Dismounting; Use M8 screw, if necessary, to detach the encoder.



- 5.1 Sicherstellen, dass die Abmessungen der Gegenwelle den Angaben im Drehgeber-Datenblatt entsprechen. Drehgeber mit einer M5- bzw. M6-Schraube (ISO 4762) mit mindestens 9-mm-Gewinde befestigen.
- 5.2 Drehgeber mit einer isolierten Drehmomentstütze befestigen. Um eine optimale Messgenauigkeit erzielen zu können, muss die Drehmomentstütze im 90-Grad-Winkel zur Befestigung montiert werden.
- 5.3 Radialversatz des Drehgebers bei langsamer Rotation und fertiger Montage überprüfen. Der Versatz darf 0,1 mm nicht überschreiten, da sonst die Lebensdauer des Drehgebers verkürzt bzw. die Systemgenauigkeit beeinträchtigt werden kann.
- 5.4 Demontage: Bei Bedarf beim Drehgeberwechsel M8-Schraube zum Lösen verwenden.



- 5.1 检查连接轴的尺寸是否符合编码器数据表中的规格。使用 M5 或 M6 螺丝 (ISO 4762) 配合最小 9 mm 螺纹来固定编码器。
- 5.2 使用绝缘扭矩臂固定编码器。安装角度必须和托架方向成 90 度，以确保最佳的测量精度。
- 5.3 通过完整组件的慢速旋转来检查编码器的径向偏移。偏移不应超过 0.1 mm，否则将缩短编码器的使用寿命或影响系统的精度。
- 5.4 如有需要，使用 M8 螺丝以在更换时拆卸编码器。

6



Electrical mounting



Elektrische Montage



电气安装

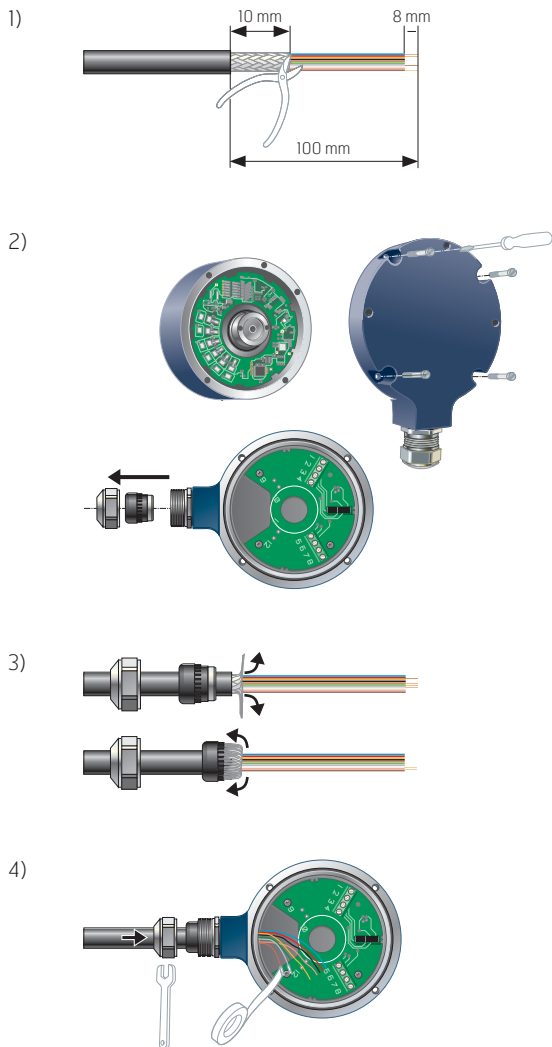

Fit cable*, using the following steps:

- Step 1. Strip the cable according to the dimensions in the illustration.
- Step 2. Open the terminal cover and unscrew the cable bushing.
- Step 3. Fold the cable shield backwards over the shell ring.
- Step 4. Connect the wires according to the product label.
Insulate any wire that is not being used.
Tighten all terminal screws (including any unused ones).

* Does not apply to models with pre-installed cable or connector.



Die elektrische Montage des Kabels*:

- Schritt 1. Kabel gemäß den Maßangaben in der Abbildung abisolieren.
- Schritt 2. Klemmendeckel öffnen und Kabeldurchführungen aufschrauben.
- Schritt 3. Kabelschirm über den Mantelring nach hinten biegen.
- Schritt 4. Leitung gemäß der Belegung wie auf dem Etikett angegeben anschließen.
Nicht verwendete Leiter isolieren.
Sämtliche Klemmschrauben anziehen (auch die nicht verwendeten).

* Gilt nicht für Modelle mit vormontiertem Kabel oder Anschlussstecker.



通过下列步骤安装电缆*:

- 第1步: 按照图示尺寸剥开电缆。
- 第2步: 打开接线盒外壳, 拧下电缆套管。
- 第3步: 将电缆屏蔽层向后对折包在环箍上。
- 第4步: 按照产品标签所示意接线。
并对未使用导线进行绝缘处理。
拧紧所有接线盒螺丝 (包括所有未使用的螺丝)。

* 不适用于预安装了电缆或连接器的型号。

7



Check points for electrical mounting



Kontrollpunkte bei elektrischer Montage



电气安装检查要点

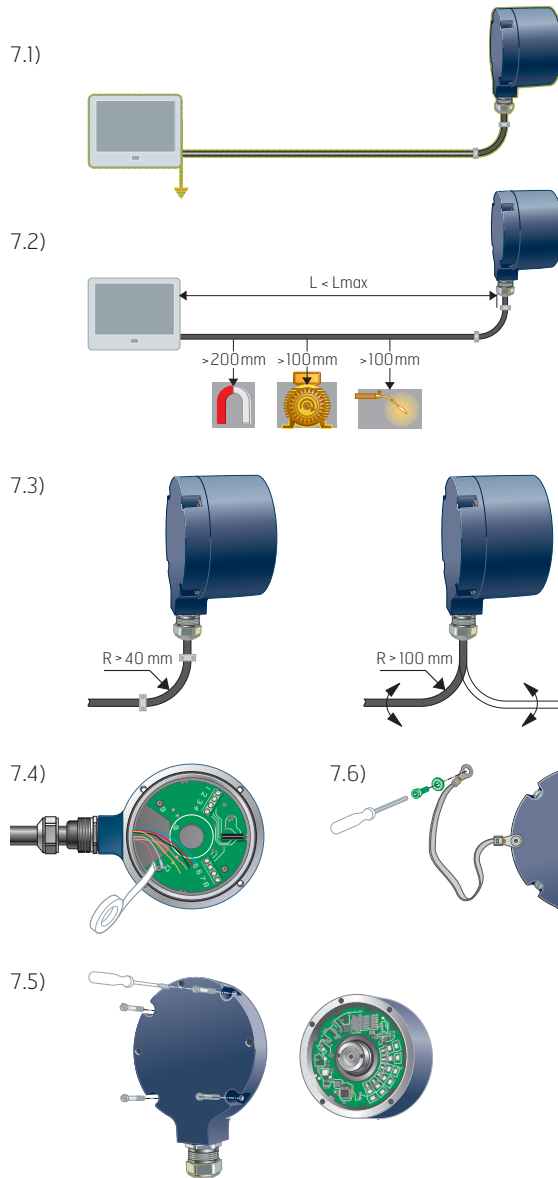

- 7.1 Use a shielded twisted-pair cable. The shielding must be connected to the chassis at both ends and be earthed at one point.
- 7.2 Keep potential sources of disturbance at the recommended distance from the cable. Make sure that the length of the cable does not exceed the value specified in the product data sheet.
- 7.3 Ensure that the cable's bending radius exceeds the permitted minimum value.
- 7.4 Treat all wires as live. Any wires not in use must be insulated.
- 7.5 Do not combine old encoder parts with new ones, when replacing a worn out encoder.
- 7.6 If the product comes with an earthing strap, this must be connected to the chassis of the machine.



- 7.1 Verwenden Sie ein geschirmtes, paarig verseiltes Kabel. Der Schirm soll auf beiden Seiten aufgelegt und an einer Stelle geerdet werden.
- 7.2 Potenzielle Störquellen auf empfohlenem Abstand halten. Sicherstellen, dass die Kabellänge nicht den im Produktdatenblatt angegebenen Wert überschreitet.
- 7.3 Sicherstellen, dass der Biegeradius des Kabels über dem zulässigen Mindestwert liegt.
- 7.4 Sämtliche Leiter als stromführend betrachten. Nicht genutzte Leiter isolieren.
- 7.5 Beim Auswechseln von Drehgebern niemals alte und neue Drehgeberkomponenten miteinander kombinieren.
- 7.6 Wird das Produkt mit einem Erdungsband geliefert, ist dieses an das Maschinengestell anzuschließen.



- 7.1 使用屏蔽双绞线电缆。屏蔽电缆必须连接到底座两端，并单点接地。
- 7.2 请将潜在干扰源放置在离电缆建议的距离外。确保电缆长度不超过产品数据表中的规定值。
- 7.3 确保电缆的弯曲半径超过所允许的最小值。
- 7.4 将所有导线视为带电线路。必须对所有未使用的导线做绝缘处理。
- 7.5 更换坏的编码器时，请勿将新旧编码器部件相互结合。
- 7.6 如果产品有接地带，必须将其连接到底座。

8



Certificates and approvals



Zertifikate und Zulassungen



执照和认证标准

8.1)

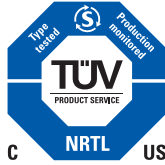

8.2)



Leine & Linde products conform to several standards and approvals. Certificates and documentation may be provided upon request to your local Leine & Linde representative.

8.1 UL/CSA standards, type approval

Most Leine & Linde products have been type tested in accordance with IEC 61010. The product box label states if the product conforms to the standard. When the product is to be operated in accordance with IEC 61010-1, the power must be supplied from a secondary circuit with current or power limitation as per IEC 61010-1:2001, section 9.3, IEC 60950-1:2005, or by a class 2 secondary circuit as specified in UL 1310.

8.2 CE marking and Declaration of conformity

Most Leine & Linde products conform to the protection requirements of Council Directive 2004/108/EC related to EMC when applicable. The product box label states if the product conforms to the standard.



Produkte von Leine & Linde erfüllen die Auflagen einer Reihe von Normen und Zulassungen. Auf Anfrage sind Zertifikate und Dokumentation beim Leine & Linde-Vertreter in Ihrer Nähe erhältlich.

8.1 Zulassung gemäß UL-/CSA-Normen

Die meisten Produkte von Leine & Linde wurden gemäß IEC 61010 typgeprüft. Auf der Produktverpackung ist angegeben, ob das Produkt der jeweiligen Norm entspricht. Bei Verwendung des Produkts gemäß IEC 61010-1 muss die Spannungsversorgung aus einem Sekundärkreis mit Strom- oder Leistungsbegrenzung nach IEC 61010-1:2001, Abschnitt 9.3 oder IEC 60950-1:2005 bzw. aus einem Sekundärkreis der Klasse 2 nach UL 1310 erfolgen.

8.2 CE-Kennzeichnung und Konformitätserklärung

Die meisten Produkte von Leine & Linde erfüllen die EMV-Sicherheitsanforderungen gemäß Richtlinie 2004/108/EG (sofern anwendbar). Auf der Produktverpackung ist angegeben, ob das Produkt der jeweiligen Norm entspricht.



莱纳林德的产品符合多项认证标准。请向您当地的莱纳林德代表索取有关执照和认证文件。

8.1 UL/CSA 标准

按类别批准 莱纳林德的大多数产品都遵照 IEC 61010 类别进行测试。产品包装盒上的标签列明该产品是否符合标准。如果莱纳林德编码器要符合 IEC 61010-1 标准运行，其电力必须由二次电路供应，且电流或电力极限需符合 IEC 61010-1:2001，9.3 项或 IEC 60950-1:2005，或依照 UL 1310 所定规格的第二类二次电路。

8.2 CE 标志标明符合要求

莱纳林德的大多数产品都符合欧盟电磁兼容性 2004/108/EC 指令的保护要求。产品包装盒上的标签列明该产品是否符合标准。

9



Accessories



Zubehör



附件

9.1)

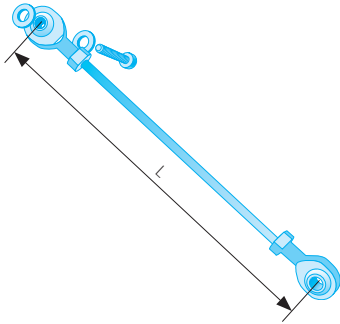

9.2)

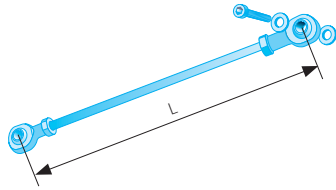

9.1 Torque arm M6
Part number 01208014, specify length (L) when ordering

9.2 Torque arm M5
Part number 01208013, specify length (L) when ordering



9.1 Drehmomentstütze M6
Artikelnummer 01208014; bei Bestellung Länge (L) angeben

9.2 Drehmomentstütze M5
Artikelnummer 01208013; bei Bestellung Länge (L) angeben



9.1 力矩臂 M6
部件编号 01208014, 订购时请标明长度 (L)

9.2 力矩臂 M5
部件编号 01208013, 订购时请标明长度 (L)



Products from Leine & Linde are usually components in larger systems. These applications require the system as a whole to be tested, and do not depend on the component specifications only.

Instructions in these mounting instructions apply to products from Leine & Linde, not for the system as a whole. If products are used in a way for which they are not intended, this is at the user's own risk.

Specifications in this document can be changed without prior notice.



Bei Produkten von Leine & Linde handelt es sich in der Regel um Komponenten, die Bestandteile größerer Anlagen sind. Diese Anwendungen erfordern Tests der gesamten Anlage und sind nicht ausschließlich von der Spezifikation dieser Komponente abhängig.

Die Anweisungen in dieser Montageanleitung gelten ausschließlich für das Produkt von Leine & Linde und nicht für die gesamte Anlage. Wird das Produkt auf eine dafür nicht vorgesehene Weise eingesetzt, erfolgt dies auf eigene Gefahr.

Änderung der Angaben in diesem Dokument vorbehalten.



莱纳林德的产品通常在大型系统中用作组件。这些应用要求对系统进行整体测试，而不仅依赖于组件规格。

本安装说明仅适用于莱纳林德的产品，而不是整个系统。如果违反原设计用途使用产品，用户需自行承担风险。

本文档中包含的信息可能随时更改。



Monteringsanvisningar på ytterligare språk finns på www.leinelinde.se



Hay instrucciones de montaje en otros idiomas en www.leinelinde.es



Инструкции по установке на других языках приведены на www.leinelinde.com